

## Air-hydro converter

**AO**  
Air-Hydro Converter

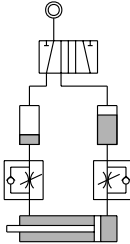

- Air/Oil systems combine the speed and low cost of air operation with the smooth, even actuator control of oil from a standard air line source. (see fig.1)



(Fig 1)



## Sizing the air-hydro converter

- Determine the volume of fluid displaced by the work cylinder by multiplying stroke by piston area.

$$V = \frac{\pi D^2}{4} \times L \times 10^{-3}$$

$\pi : 3.14159$

D: Piston area of work cylinder (mm)



L: Stroke of work cylinder (mm)

V: Volume of work cylinder (cm<sup>3</sup>)

## Specification

Type	AOF		AOL	
Bore sizes of converter (mm)	φ 40	φ 63	φ 80	φ 100
Standard length (mm)	150,175,200,225,250,275,300,325,350,375,400,425,450,475,500			
Power fluid	Filtered oil (ISO Vg32)			
Material of converter barrel	Anodised aluminium alloy			
Max. pressure (MPa)	1.03			
The range of temperature (°C)	-10~+60			

## How to order

AOF		40 /	200	
Type		Bore	Converter length	
		40—φ 40mm 63—φ 63mm 80—φ 80mm 100—φ 100mm	150—150mm 175—175mm 200—200mm 225—225mm 250—250mm 275—275mm 300—300mm 325—325mm	350—350mm 375—375mm 400—400mm 425—425mm 450—450mm 475—475mm 500—500mm
				

## Air-hydro converter

- Refer to Table 1 to find the bore and length equal to or greater than this volume. In general, longer converter of smaller bore size are most economical.
- Suggested minimum internal length is 150mm.
- AIR-HYDRO converter should be sized so that the oil level does not change more than 150 mm/sec.
- AIR-HYDRO converter should be mounted vertically at the highest point in the system to allow self-bleeding of the converter.

## Maximum useable capacities (Table 1)

(cm<sup>3</sup>)

Bore (mm)	Converter length (mm)															
	150	175	200	225	250	275	300	325	350	375	400	425	450	475	500	
φ 40	94	110	125	141	157	172	188	204	220	235	251	267	282	298	314	
φ 63	237	277	316	356	395	435	475	514	554	594	633	673	712	752	791	
φ 80	377	440	502	565	628	691	754	816	880	942	1005	1068	1131	1194	1256	
φ 100	589	687	785	883	981	1080	1178	1276	1374	1472	1570	1669	1767	1865	1963	

Note: the capacity mentioned above includes 50% of reservation.

## Oil feeding procedure

1. Pull the piston to the oil feeding end.
2. Open throttle valve fully.
3. Open the bolt of the oil feeding hole on the top of the hydro-pneumatic converters.
4. Inject oil in the gravity direction.
5. Inject oil to the position limit, lock the bolt and shut the hole.
6. After that, pull the piston to the other end with pressure of 0.2MPa.
7. Repeat step 2.-5. on the other end.
8. After that, make the piston have a reciprocating motion for 2~3 times with pressure of 0.2MPa.

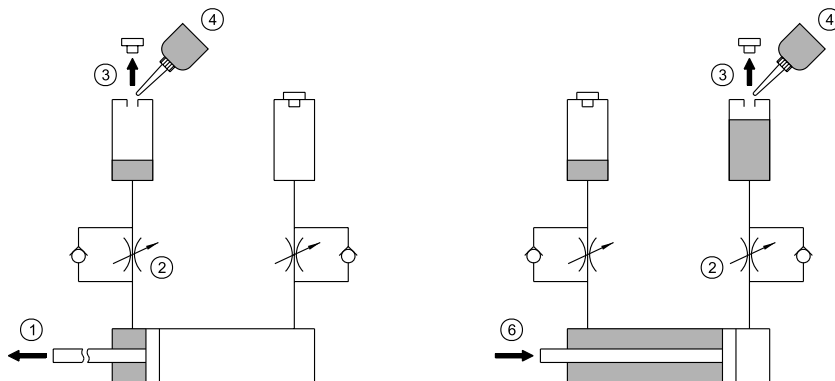

AS

AN

AO

AH

AP

## Dimensional features

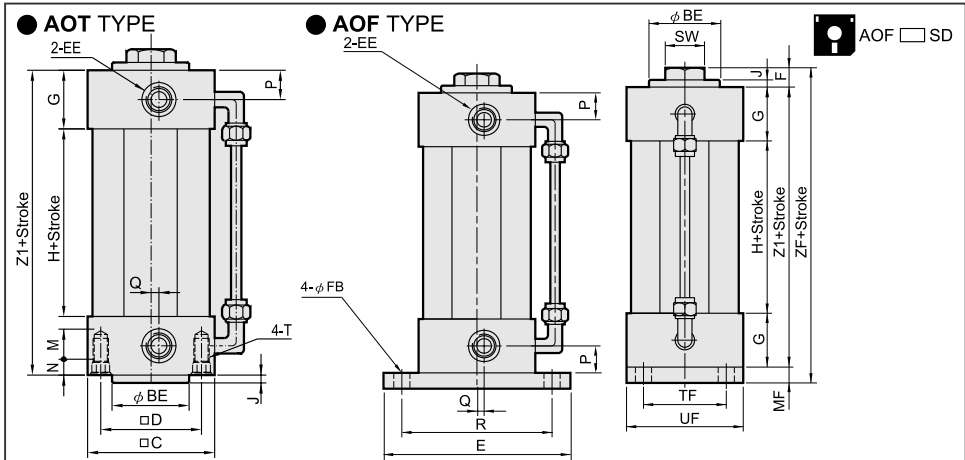

## Dimensional Table

Bore	BE	C	D	E	EE	F	FB	G	H	J	M	N	MF	P	Q	R	T	SW	TF	UF	Z1	ZF
φ 40	35	53	38	90	G 1/4	14	9	30	30	5	9	6	10	15	5	72	M6	26	36	55	90	114
φ 63	45	75	56.5	120	G 3/8	14	9	32	30	5	12	6	12	16	8	100	M8	26	50	75	94	120
φ 80	45	95	72	153	G 3/8	15	12	38	30	6	16	6	16	19	9	126	M10	26	63	95	106	137
φ 100	55	115	89	178	G 1/2	15	14	40	30	6	16	6	16	20	7	150	M10	26	75	115	110	141

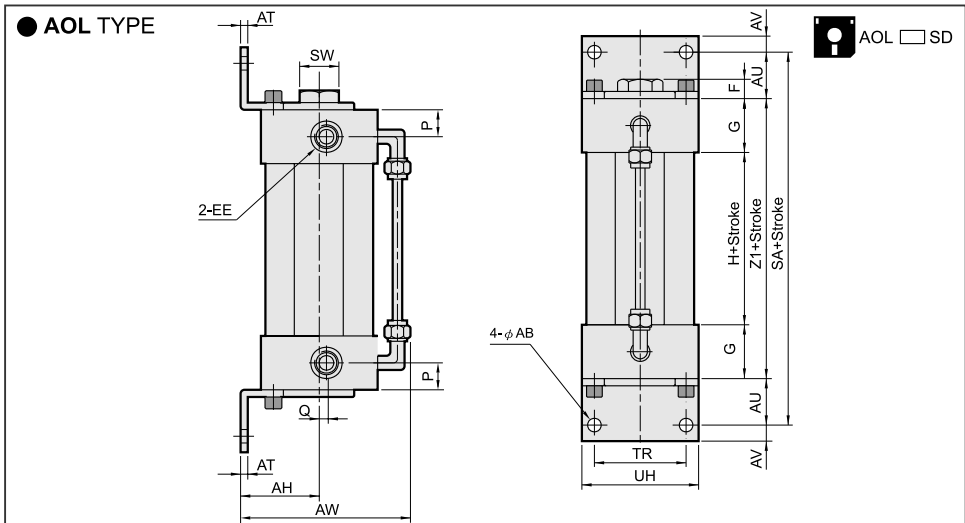

## Dimensional Table

Bore	AB	AH	AT	AU	AV	AW	EE	F	G	H	P	Q	SA	SW	TR	UH	Z1
φ 40	9	36	5	28	10	84	G 1/4	14	30	30	15	5	146	26	36	53	90
φ 63	9	50	5	32	10	109	G 3/8	14	32	30	16	8	158	26	50	75	94
φ 80	12	63	6	41	13	132	G 3/8	15	38	30	19	9	188	26	63	95	106
φ 100	14	71	6	41	15	150	G 1/2	15	40	30	20	7	192	26	75	115	110