

單雙動氣缸

單動常入型	DJI..N	
單動常入型附磁性感應	DJI..M	
單動常出型	DJO..N	
單動常出型附磁性感應	DJO..M	
雙動標準型	DJA..N	
雙動型附磁性感應	DJA..M	
雙動雙軸型	DJD..N	
雙動雙軸型附磁性感應	DJD..M	

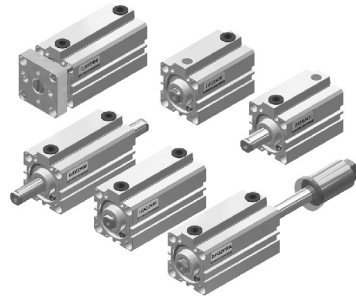

- DJ系列可附磁性感應。
- 本系列外形輕薄，有效的節省空間。

雙軸行程可調	DJN..N	
雙軸行程可調(附磁性感應)	DJN..M	

特性資料

氣缸內徑 (mm)	φ 12	φ 16	φ 20	φ 25	φ 32	φ 40	φ 50	φ 63	φ 80	φ 100
標準行程 (mm)	10, 15, 20, 25, 30, 35, 40, 45, 50, 55, 60, 75, 85, 100, 125, 150									
雙動行程範圍 (mm)	最大30		最大150							
工作媒體	已濾清之壓縮空氣(潤滑或未潤滑)									
使用壓力範圍 (MPa)	0.2~0.7		0.15~0.7			0.1~0.7				
使用溫度範圍 (°C)	-10~+60									

標示法

DJN	20	M	10	Z	A	LN01D	×	2
型式	內徑	磁性感應	行程	軸端型式	可調行程	近接開關		感應器數量
	12—φ 12mm 16—φ 16mm 20—φ 20mm 25—φ 25mm 32—φ 32mm 40—φ 40mm 50—φ 50mm 63—φ 63mm 80—φ 80mm 100—φ 100mm	M:內附磁性感應 N:無附磁性感應	10—10mm 15—15mm 20—20mm 25—25mm 30—30mm 35—35mm 40—40mm 45—45mm 50—50mm 55—55mm 60—60mm 75—75mm 85—85mm 100—100mm 125—125mm 150—150mm		無記號:標準型 A:可調25mm B:可調40mm <small>註:此編號僅適用可調形式。</small>			1:1個 2:2個
				無記號:軸身為內牙				
				Z:軸身為外牙				

註:
1.可選用NPN&PNP型式(3線式・24VDC)。
2.可選用輸出接點為接頭型式。
3.請翻閱4-1.3與4-1.5。

雙動型外形尺寸

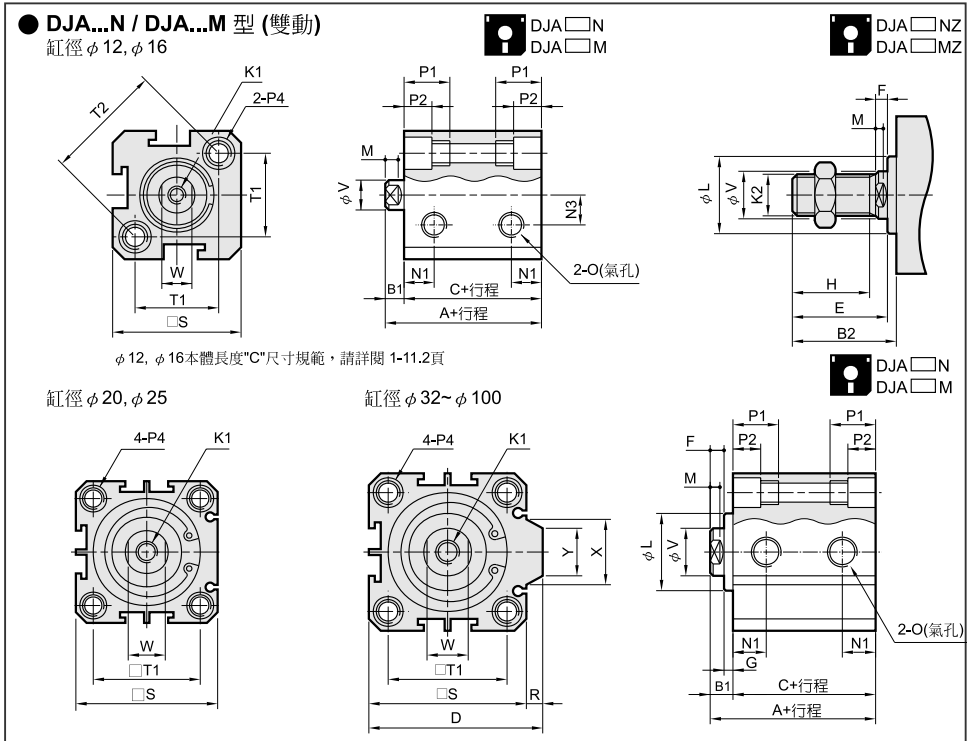

外形尺寸表

右列行程之本體長度“C”尺寸相同: (5,10)(15,20)(25,30)(35,40)(45,50)(55,60)

缸徑	DJA...N		DJA...M		B1	B2	D	E	F	G	H	K1 (內牙)	K2 (外牙)	L	M	N1
	A	C	A	C												
φ 12	25	20.5	35	30.5	4.5	14.5	-	14.5	4.5	-	9	M3×0.5P×7L	M5×0.8	9.8	3	7.5
φ 16	25.2	21.5	35.2	31.5	3.7	13.7	-	13.7	3.7	-	9	M3×0.5P×7L	M5×0.8	10	3	8
φ 20	25	19.5	35	29.5	5.5	19.5	-	18	4	1.5	13	M4×0.7P×10L	M6×1.0	13	3	7.5
φ 25	27.2	21.2	37.2	31.2	6	22	-	20.1	4.1	1.9	15	M5×0.8P×10L	M8×1.25	17	3	8
φ 32	31	24	41	34	7	24	50	20.7	3.7	3.3	16	M6×1.0P×14L	M10×1.25	22	3	9
φ 40	33.5	26.5	43.5	36.5	7	34	58.5	30.7	3.7	3.3	25	M8×1.25P×14L	M14×1.5	28	3	10
φ 50	37.6	28.6	47.6	38.6	9	36	71.5	32.1	5.1	3.9	25	M10×1.5P×15L	M18×1.5	38	3	10.8
φ 63	41	32.5	51	42.5	8.5	35.5	84.5	31.6	4.6	3.9	25	M10×1.5P×15L	M18×1.5	40	3	11
φ 80	52	41.3	62	51.3	10.7	43.7	104	38.7	5.7	5	30	M14×1.5P×20L	M22×1.5	45	4	13
φ 100	54	45.3	64	55.3	8.7	41.7	124	38.7	5.7	3	30	M16×2.0P×20L	M22×1.5	45	4	15

缸徑	N3	O	P1	P2	P4	R	S	T1	T2	V	W	X	Y
φ 12	6	M5×0.8	10.5	4.5	φ 4.3,2—M5×0.8P×6L, 柱孔6.5×4.5深	-	25	15.7	22.2	6	5	-	-
φ 16	6.5	M5×0.8	10.5	4.5	φ 4.3,2—M5×0.8P×6L, 柱孔6.5×4.5深	-	29	19.8	28	6	5	-	-
φ 20	-	M5×0.8	11	5	φ 4.3,2—M5×0.8P×6L, 柱孔7×5深	-	34	24	-	8	6	-	-
φ 25	-	M5×0.8	14	6	φ 5.1,2—M6×1.0P×8L, 柱孔8×6深	-	40	28	-	10	8	-	-
φ 32	-	PT 1/8	14	6	φ 5.1,2—M6×1.0P×8L, 柱孔8×6深	6	44	34	-	12	10	15	13.6
φ 40	-	PT 1/8	18	8	φ 6.8,2—M8×1.25P×10L, 柱孔10×8深	6.5	52	40	-	16	14	15	13.6
φ 50	-	PT 1/4	18.5	8.5	φ 6.8,2—M8×1.25P×10L, 柱孔11×8.5深	9.5	62	48	-	20	17	21.6	19
φ 63	-	PT 1/4	18.5	8.5	φ 6.8,2—M8×1.25P×10L, 柱孔11×8.5深	9.5	75	60	-	20	17	32	20.5
φ 80	-	PT 3/8	22.5	10.5	φ 10.4,2—M12×1.75P×12L, 柱孔14×10.5深	10	94	74	-	25	22	38.8	26.8
φ 100	-	PT 3/8	28	13	φ 12.5,2—M14×2.0P×15L, 柱孔18.5×13深	10	114	90	-	25	22	37.3	26.3

雙動雙軸型外形尺寸

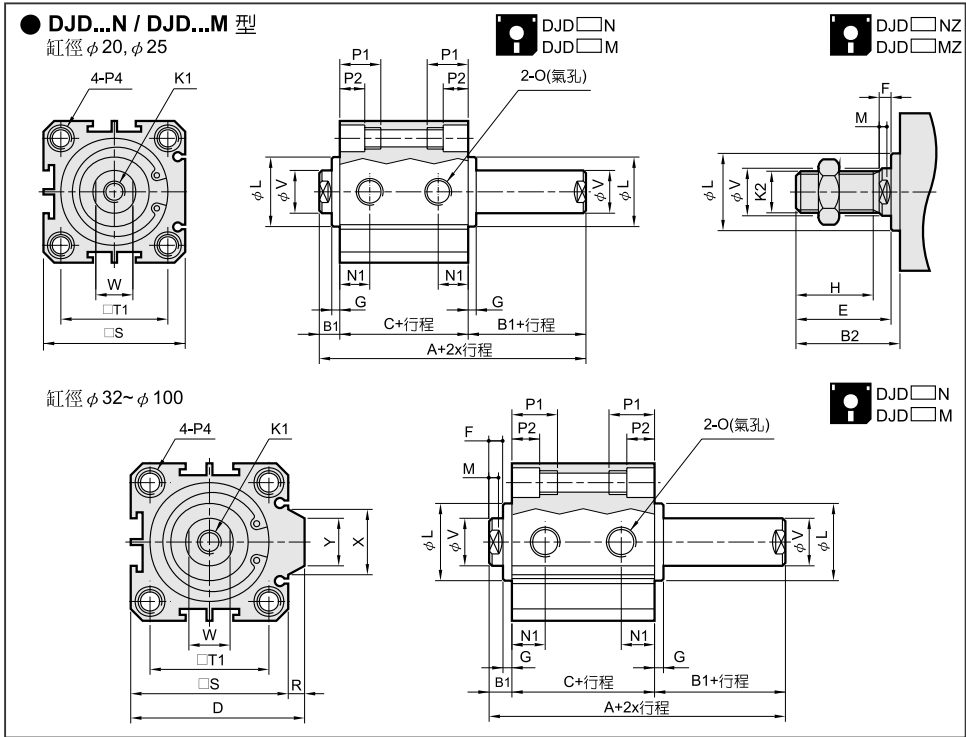

- DA
- DP
- DS
- DQ
- DB
- DN
- BN
- ST
- NT
- DU
- DJ
- TA
- GP
- GS
- GM
- GT
- RT
- CT
- CH

外形尺寸表

右列行程之本體長度“C”尺寸相同: (5.10)(15.20)(25.30)(35.40)(45.50)(55.60)

缸徑	DJD...N		DJD...M		B1	B2	D	E	F	G	H	K1(內牙)		K2(外牙)		L	M	N1
	A	C	A	C								M8×1.25P×14L	M14×1.5	M18×1.5	M22×1.5			
φ 20	30.5	19.5	40.5	29.5	5.5	19.5	-	18	4	1.5	13	M4×0.7P×10L	M6×1.0	13	3	7.5		
φ 25	33.2	21.2	43.2	31.2	6	22	-	20.1	4.1	1.9	15	M5×0.8P×10L	M8×1.25	17	3	8		
φ 32	38	24	48	34	7	24	50	20.7	3.7	3.3	16	M6×1.0P×14L	M10×1.25	22	3	9		
φ 40	40.5	26.5	50.5	36.5	7	34	58.5	30.7	3.7	3.3	25	M8×1.25P×14L	M14×1.5	28	3	10		
φ 50	46.6	28.6	56.6	38.6	9	36	71.5	32.1	5.1	3.9	25	M10×1.5P×15L	M18×1.5	38	3	10.8		
φ 63	49.5	32.5	59.5	42.5	8.5	35.5	84.5	31.6	4.6	3.9	25	M10×1.5P×15L	M18×1.5	40	3	11		
φ 80	62.7	41.3	72.7	51.3	10.7	43.7	104	38.7	5.7	5	30	M14×1.5P×20L	M22×1.5	45	4	13		
φ 100	62.7	45.3	72.7	55.3	8.7	41.7	124	38.7	5.7	3	30	M16×2.0P×20L	M22×1.5	45	4	15		

缸徑	N3	O	P1	P2	P4				R	S	T1	V	W	X	Y
					φ 4.3,2	φ 5.1,2	φ 5.1,2	φ 6.8,2							
φ 20	-	M5×0.8	11	5	φ 4.3,2—M5×0.8P×6L, 柱孔7×5深	-	34	24	8	6	-	-	-	-	-
φ 25	-	M5×0.8	14	6	φ 5.1,2—M6×1.0P×8L, 柱孔8×6深	-	40	28	10	8	-	-	-	-	-
φ 32	-	PT 1/8	14	6	φ 5.1,2—M6×1.0P×8L, 柱孔8×6深	6	44	34	12	10	15	13.6			
φ 40	-	PT 1/8	18	8	φ 6.8,2—M8×1.25P×10L, 柱孔10×8深	6.5	52	40	16	14	15	13.6			
φ 50	-	PT 1/4	18.5	8.5	φ 6.8,2—M8×1.25P×10L, 柱孔11×8.5深	9.5	62	48	20	17	21.6	19			
φ 63	-	PT 1/4	18.5	8.5	φ 6.8,2—M8×1.25P×10L, 柱孔11×8.5深	9.5	75	60	20	17	32	20.5			
φ 80	-	PT 3/8	22.5	10.5	φ 10.4,2—M12×1.75P×12L, 柱孔14×10.5深	10	94	74	25	22	38.8	26.8			
φ 100	-	PT 3/8	28	13	φ 12.5,2—M14×2.0P×15L, 柱孔18.5×13深	10	114	90	25	22	37.3	26.3			

外形尺寸

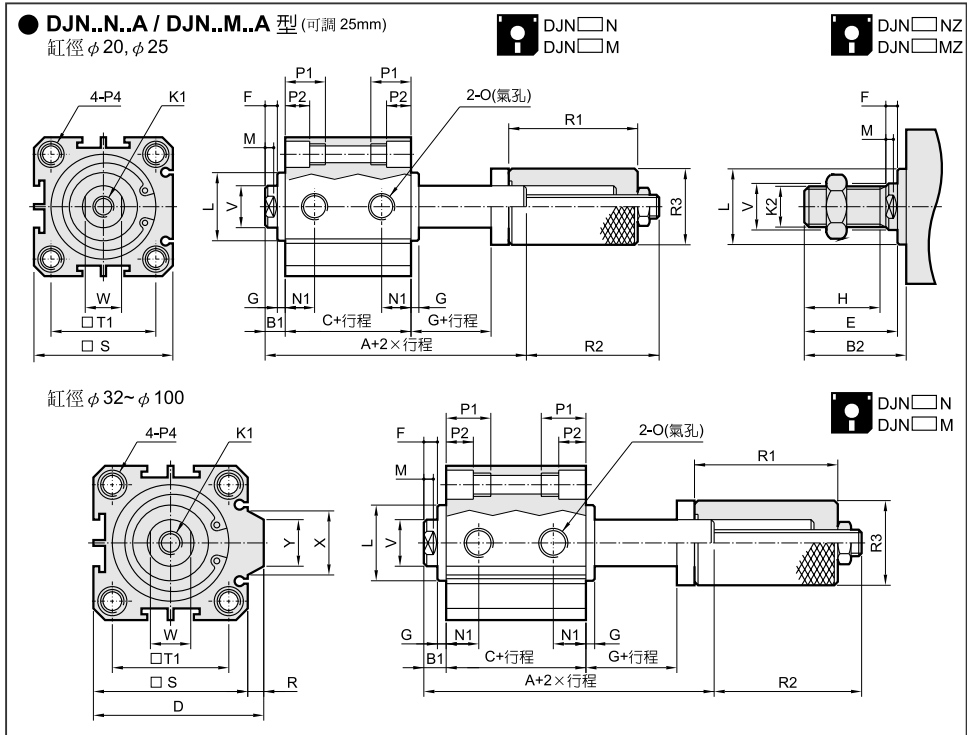

外形尺寸表

右列行程之本體長度“C”尺寸相同: (5,10)(15,20)(25,30)(35,40)(45,50)(55,60)

缸徑	DJN...N		DJN...M		B1	B2	D	E	F	G	H	K1(內牙)	K2(外牙)	L	M	N1
	A	C	A	C												
φ20	26.5	19.5	36.5	29.5	5.5	19.5	-	18	4	1.5	13	M4×0.7P×10L	M6×1.0	13	3	7.5
φ25	29.1	21.2	39.1	31.2	6	22	-	20.1	4.1	1.9	15	M5×0.8P×10L	M8×1.25	17	3	8
φ32	34.3	24	44.3	34	7	24	50	20.7	3.7	3.3	16	M6×1.0P×14L	M10×1.25	22	3	9
φ40	36.8	26.5	46.8	36.5	7	34	58.5	30.7	3.7	3.3	25	M8×1.25P×14L	M14×1.5	28	3	10
φ50	41.5	28.6	51.5	38.6	9	36	71.5	32.1	5.1	3.9	25	M10×1.5P×15L	M18×1.5	38	3	10.8
φ63	44.9	32.5	54.9	42.5	8.5	35.5	84.5	31.6	4.6	3.9	25	M10×1.5P×15L	M18×1.5	40	3	11
φ80	57	41.3	67	51.3	10.7	43.7	104	38.7	5.7	5	30	M14×1.5P×20L	M22×1.5	45	4	13
φ100	57	45.3	67	55.3	8.7	41.7	124	38.7	5.7	3	30	M16×2.0P×20L	M22×1.5	45	4	15

缸徑	O	P1	P2	P4				R	R1	R2	R3	S	T1	V	W	X	Y
				行程	行程	行程	行程										
φ20	M5×0.8	11	5	φ4.3,2—M5×0.8P×6L, 柱孔7×5深	-	31	39.5	16	34	24	8	6	-	-	-	-	
φ25	M5×0.8	14	6	φ5.1,2—M6×1.0P×8L, 柱孔8×6深	-	33	43	20	40	28	10	8	-	-	-	-	
φ32	PT 1/8	14	6	φ5.1,2—M6×1.0P×8L, 柱孔8×6深	6	33	44.5	25	44	34	12	10	15	13.6	-	-	
φ40	PT 1/8	18	8	φ6.8,2—M8×1.25P×10L, 柱孔10×8深	6.5	35	50	32	62	40	16	14	15	13.6	-	-	
φ50	PT 1/4	18.5	8.5	φ6.8,2—M8×1.25P×10L, 柱孔11×8.5深	9.5	37	57	38	62	48	20	17	21.6	19	-	-	
φ63	PT 1/4	18.5	8.5	φ6.8,2—M8×1.25P×10L, 柱孔11×8.5深	9.5	37	57	38	75	60	20	17	32	20.5	-	-	
φ80	PT 3/8	22.5	10.5	φ10.4,2—M12×1.75P×12L, 柱孔14×10.5深	10	37	59.5	44	94	74	25	22	38.8	26.8	-	-	
φ100	PT 3/8	28	13	φ12.5,2—M14×2.0P×15L, 柱孔18.5×13深	10	37	59.5	44	114	90	25	22	37.3	26.3	-	-	

外形尺寸

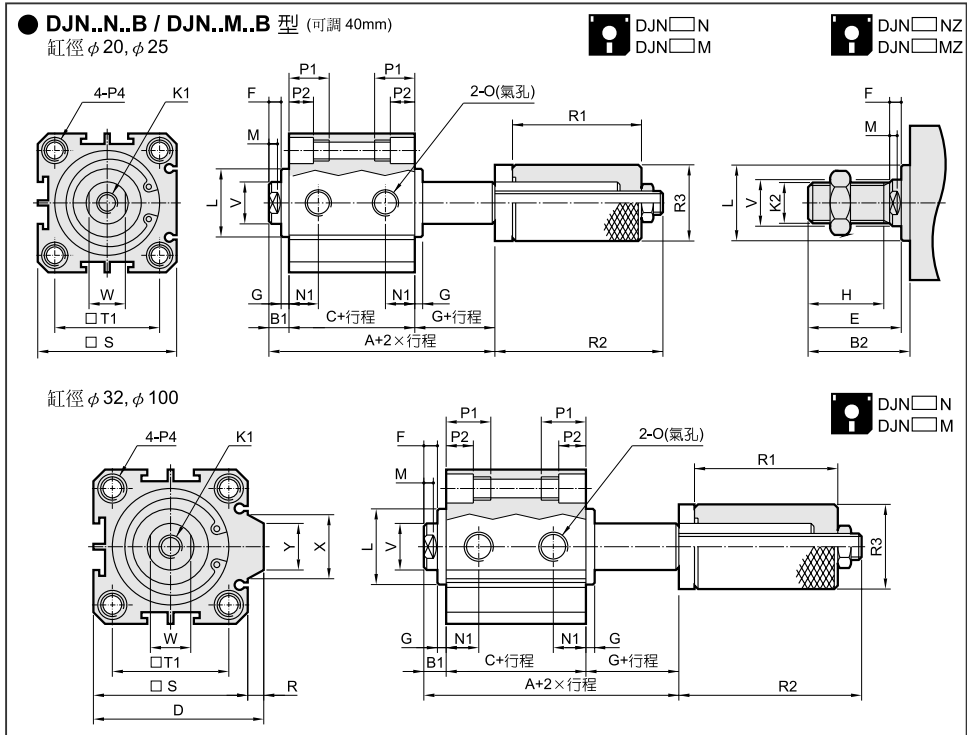

外形尺寸表

右列行程之本體長度“C”尺寸相同: (5.10)(15.20)(25.30)(35.40)(45.50)(55.60)

缸徑	DJN...N		DJN...M		B1	B2	D	E	F	G	H	K1(內牙)	K2(外牙)	L	M	N1
	A	C	A	C												
φ 20	26.5	19.5	36.5	29.5	5.5	19.5	-	18	4	1.5	13	M4×0.7P×10L	M6×1.0	13	3	7.5
φ 25	29.1	21.2	39.5	31.2	6	22	-	20.1	4.1	1.9	15	M5×0.8P×10L	M8×1.25	17	3	8
φ 32	34.3	24	44.3	34	7	24	50	20.7	3.7	3.3	16	M6×1.0P×14L	M10×1.25	22	3	9
φ 40	36.8	26.5	46.8	36.5	7	34	58.5	30.7	3.7	3.3	25	M8×1.25P×14L	M14×1.5	28	3	10
φ 50	41.5	28.6	51.5	38.6	9	36	71.5	32.1	5.1	3.9	25	M10×1.5P×15L	M18×1.5	38	3	10.8
φ 63	44.9	32.5	54.9	42.5	8.5	35.5	84.5	31.6	4.6	3.9	25	M10×1.5P×15L	M18×1.5	40	3	11
φ 80	57	41.3	67	51.3	10.7	43.7	104	38.7	5.7	5	30	M14×1.5P×20L	M22×1.5	45	4	13
φ 100	57	45.3	67	55.3	8.7	41.7	124	38.7	5.7	3	30	M16×2.0P×20L	M22×1.5	45	4	15

缸徑	O	P1	P2	P4				R	R1	R2	R3	S	T1	V	W	X	Y
φ 20	M5×0.8	11	5	φ 4.3,2—M5×0.8P×6L, 柱孔7×5深				-	56	64.5	16	34	24	8	6	-	-
φ 25	M5×0.8	14	6	φ 5.1,2—M6×1.0P×8L, 柱孔8×6深				-	58	68	20	40	28	10	8	-	-
φ 32	PT 1/8	14	6	φ 5.1,2—M6×1.0P×8L, 柱孔8×6深				6	58	69.5	25	44	34	12	10	15	13.6
φ 40	PT 1/8	18	8	φ 6.8,2—M8×1.25P×10L, 柱孔10×8深				6.5	60	75	32	62	40	16	14	15	13.6
φ 50	PT 1/4	18.5	8.5	φ 6.8,2—M8×1.25P×10L, 柱孔11×8.5深				9.5	62	82	38	62	48	20	17	21.6	19
φ 63	PT 1/4	18.5	8.5	φ 6.8,2—M8×1.25P×10L, 柱孔11×8.5深				9.5	62	82	38	75	60	20	17	32	20.5
φ 80	PT 3/8	22.5	10.5	φ 10.4,2—M12×1.75P×12L, 柱孔14×10.5深				10	62	84.5	44	94	74	25	22	38.8	26.8
φ 100	PT 3/8	28	13	φ 12.5,2—M14×2.0P×15L, 柱孔18.5×13深				10	62	84.5	44	114	90	25	22	37.3	26.3

- DA
- DP
- DS
- DQ
- DB
- DN
- BN
- ST
- NT
- DU
- DJ
- TA
- GP
- GS
- GM
- GT
- RT
- CT
- CH

近接開關安裝尺寸

- DJA 型
- DJD 型

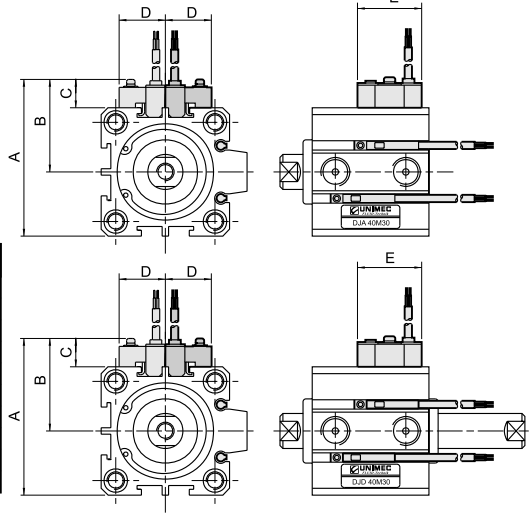

近接開關尺寸表

缸徑	近接開關型式	A	B	C	D	E
12	LN01D	34.5	22	9.5	15.5	22
16	LN01D	38.5	24	9.5	15.5	22
20	LN01D	43.5	26.5	9.5	15.5	22
25	LN01D	49.5	29.5	9.5	15.5	22
32	LN01D	53.5	31.5	9.5	15.5	22
40	LN01D	61.5	35.5	9.5	15.5	22
50	LN01D	71.5	40.5	9.5	15.5	22
63	LN01D	84.5	47	9.5	15.5	22
80	LN01D	103.5	56.5	9.5	15.5	22
100	LN01D	123.5	66.5	9.5	15.5	22

修理包訂購方式

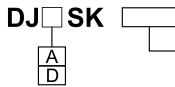

缸徑	修理包	缸徑	修理包
12	DJASK12 - 包含 No.9,10,12	12	DJDSK12 - 包含 No.9,10,12
16	DJASK16 - 包含 No.9,10,12	16	DJDSK16 - 包含 No.9,10,12
20	DJASK20 - 包含 No.9,10,12	20	DJDSK20 - 包含 No.9,10,12
25	DJASK25 - 包含 No.9,10,12	25	DJDSK25 - 包含 No.9,10,12
32	DJASK32 - 包含 No.9,10,12	32	DJDSK32 - 包含 No.9,10,12
40	DJASK40 - 包含 No.9,10,12	40	DJDSK40 - 包含 No.9,10,12
50	DJASK50 - 包含 No.9,10,12	50	DJDSK50 - 包含 No.9,10,12
63	DJASK63 - 包含 No.9,10,12	63	DJDSK63 - 包含 No.9,10,12
80	DJASK80 - 包含 No.9,10,12	80	DJDSK80 - 包含 No.9,10,12
100	DJASK100 - 包含 No.9,10,12	100	DJDSK100 - 包含 No.9,10,12

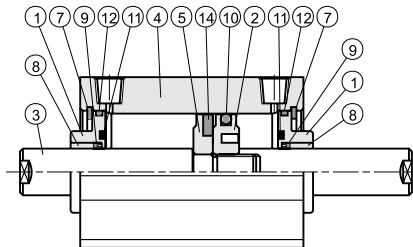
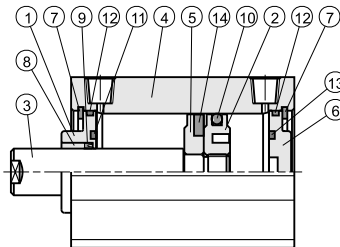

零件表

No.	零件名稱	數量	No.	零件名稱	數量	No.	零件名稱	數量
1	前蓋	1	6	後蓋	1	11	前蓋墊片	1
2	活塞本體	1	7	孔用扣環	2	12	前後蓋O型環	2
3	活塞桿	1	8	乾式軸承	1	13	後蓋墊片	1
4	氣缸本體	1	9	軸封	1	14	磁環	1
5	磁環座	1	10	活塞迫緊	1	15		

單動常入型外形尺寸

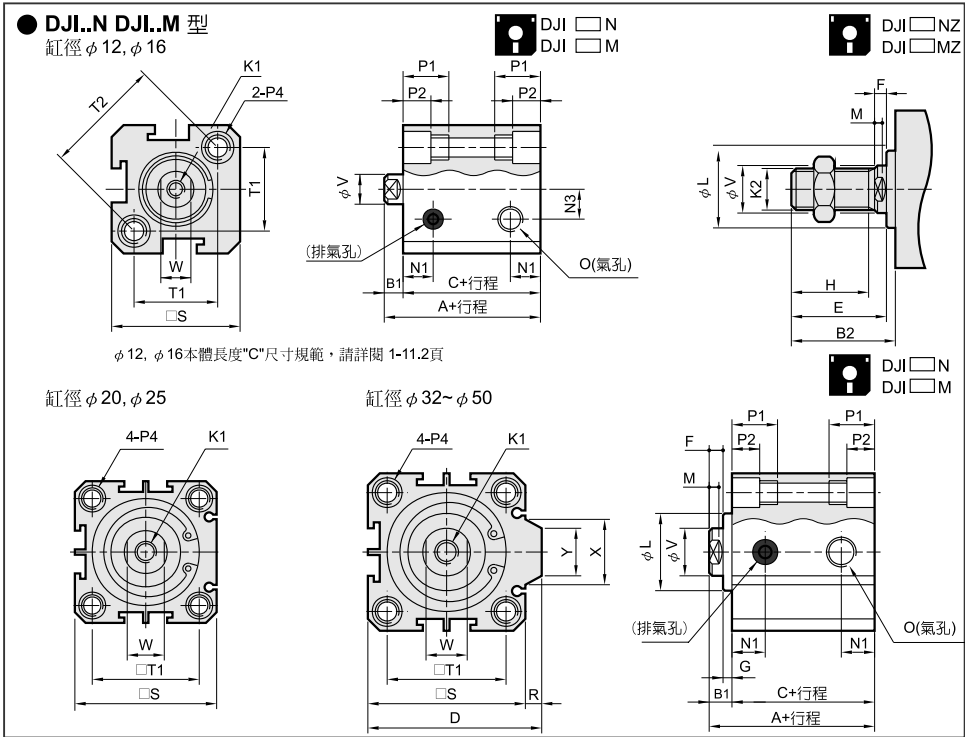

φ 12, φ 16本體長度“C”尺寸規範，請詳閱 1-11.2頁

缸徑 φ 20, φ 25

缸徑 φ 32~φ 50

外形尺寸表

右列行程之本體長度“C”尺寸相同：(5,10)(15,20)(25,30)(35,40)(45,50)(55,60)

缸徑	DJI..N				DJI..M				B1	B2	D	E	F	G	H	K1(內牙)	K2(外牙)	L
	行程 5-15		行程 20-30		行程 5-10		行程 20											
	A	C	A	C	A	C	A	C										
φ 12	35	30.5	35	30.5	45	40.5	45	40.5	4.5	14.5	-	14.5	4.5	-	9	M3×0.5P×7L	M5×0.8	9.8
φ 16	35.2	31.5	35.2	31.5	45.2	41.5	45.2	41.5	3.7	13.7	-	13.7	3.7	-	9	M3×0.5P×7L	M5×0.8	10
φ 20	35	29.5	35	29.5	45	39.5	45	39.5	5.5	19.5	-	18	4	1.5	13	M4×0.7P×10L	M6×1.0	13
φ 25	37.2	31.2	37.2	31.2	47.2	41.2	47.2	41.2	6	22	-	20.1	4.1	2	15	M5×0.8P×10L	M8×1.25	17
φ 32	41	34	41	34	51	44	51	44	7	24	50	20.7	3.7	3.3	16	M6×1.0P×14L	M10×1.25	22
φ 40	43.5	36.5	43.5	36.5	53.5	46.5	53.5	46.5	7	34	58.5	30.7	3.7	3.3	25	M8×1.25P×14L	M14×1.5	28
φ 50	47.6	38.6	47.6	38.6	57.6	48.6	57.6	48.6	9	36	71.5	32.1	5.1	3.9	25	M10×1.5P×15L	M18×1.5	38

缸徑	M	N1	N3	O	P1	P2	P4	R	S	T1	T2	V	W	X	Y
φ 12	3	7.5	6	M5×0.8	10.5	4.5	φ 4.3,2—M5×0.8P×6L, 柱孔6.5×4.5深	-	25	15.7	22.2	6	5	-	-
φ 16	3	8	6.5	M5×0.8	10.5	4.5	φ 4.3,2—M5×0.8P×6L, 柱孔6.5×4.5深	-	29	19.8	28	6	5	-	-
φ 20	3	7.5	-	M5×0.8	11	5	φ 4.3,2—M5×0.8P×6L, 柱孔7×5深	-	34	24	-	8	6	-	-
φ 25	3	8	-	M5×0.8	14	6	φ 5.1,2—M6×1.0P×8L, 柱孔8×6深	-	40	28	-	10	8	-	-
φ 32	3	9	-	PT 1/8	14	6	φ 5.1,2—M6×1.0P×8L, 柱孔8×6深	6	44	34	-	12	10	15	13.6
φ 40	3	10	-	PT 1/8	18	8	φ 6.8,2—M8×1.25P×10L, 柱孔10×8深	6.5	52	40	-	16	14	15	13.6
φ 50	3	10.8	-	PT 1/4	18.5	8.5	φ 6.8,2—M8×1.25P×10L, 柱孔11×8.5深	9.5	62	48	-	20	17	21.6	19

- DA
- DP
- DS
- DQ
- DB
- DN
- BN
- ST
- NT
- DU
- DJ
- TA
- GP
- GS
- GM
- GT
- RT
- CT
- CH

單動常出型外形尺寸

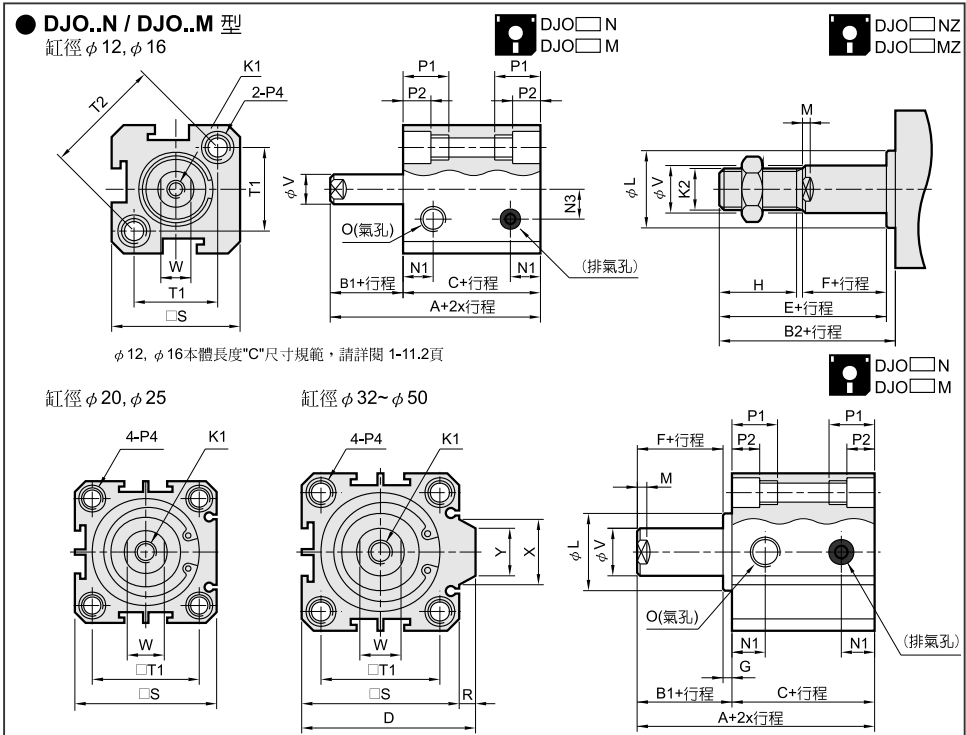

φ 12, φ 16本體長度“C”尺寸規範，請詳閱 1-11.2頁

缸徑 φ 20, φ 25

缸徑 φ 32~φ 50

外形尺寸表

右列行程之本體長度“C”尺寸相同：(5,10)(15,20)(25,30)(35,40)(45,50)(55,60)

缸徑	DJO..N				DJO..M				B1	B2	D	E	F	G	H	K1(內牙)	K2(外牙)	L
	行程 5-15	行程 20-30		行程 5-10	行程 20													
φ 12	35	30.5	35	30.5	45	40.5	45	40.5	4.5	14.5	-	14.5	4.5	-	9	M3×0.5P×7L	M5×0.8	9.8
φ 16	35.2	31.5	35.2	31.5	45.2	41.5	45.2	41.5	3.7	13.7	-	13.7	3.7	-	9	M3×0.5P×7L	M5×0.8	10
φ 20	35	29.5	35	29.5	45	39.5	45	39.5	5.5	19.5	-	18	4	1.5	13	M4×0.7P×10L	M6×1.0	13
φ 25	37.2	31.2	37.2	31.2	47.2	41.2	47.2	41.2	6	22	-	20.1	4.1	2	15	M5×0.8P×10L	M8×1.25	17
φ 32	41	34	41	34	51	44	51	44	7	24	50	20.7	3.7	3.3	16	M6×1.0P×14L	M10×1.25	22
φ 40	43.5	36.5	43.5	36.5	53.5	46.5	53.5	46.5	7	34	58.5	30.7	3.7	3.3	25	M8×1.25P×14L	M14×1.5	28
φ 50	47.6	38.6	47.6	38.6	57.6	48.6	57.6	48.6	9	36	71.5	32.1	5.1	3.9	25	M10×1.5P×15L	M18×1.5	38

缸徑	M	N1	N3	O	P1	P2	P4				R	S	T1	T2	V	W	X	Y
	φ 12	3	7.5	6	M5×0.8	10.5	4.5	φ 4.3,2—M5×0.8P×6L, 柱孔6.5×4.5深				-	25	15.7	22.2	6	5	-
φ 16	3	8	6.5	M5×0.8	10.5	4.5	φ 4.3,2—M5×0.8P×6L, 柱孔6.5×4.5深				-	29	19.8	28	6	5	-	-
φ 20	3	7.5	-	M5×0.8	11	5	φ 4.3,2—M5×0.8P×6L, 柱孔7×5深				-	34	24	-	8	6	-	-
φ 25	3	8	-	M5×0.8	14	6	φ 5.1,2—M6×1.0P×8L, 柱孔8×6深				-	40	28	-	10	8	-	-
φ 32	3	9	-	PT 1/8	14	6	φ 5.1,2—M6×1.0P×8L, 柱孔8×6深				6	44	34	-	12	10	15	13.6
φ 40	3	10	-	PT 1/8	18	8	φ 6.8,2—M8×1.25P×10L, 柱孔10×8深				6.5	52	40	-	16	14	15	13.6
φ 50	3	10.8	-	PT 1/4	18.5	8.5	φ 6.8,2—M8×1.25P×10L, 柱孔11×8.5深				9.5	62	48	-	20	17	21.6	19

近接開關安裝尺寸

- DJI 型
- DJO 型

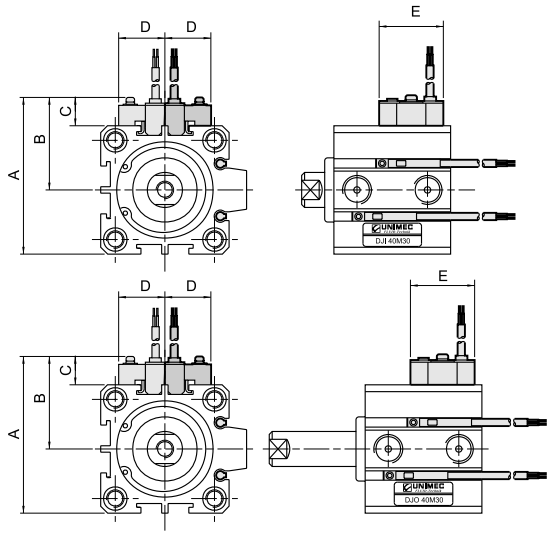

近接開關尺寸表

缸徑	近接開關型式	A	B	C	D	E
φ 12	LN01D	34.5	22	9.5	15.5	22
φ 16	LN01D	38.5	24	9.5	15.5	22
φ 20	LN01D	43.5	26.5	9.5	15.5	22
φ 25	LN01D	49.5	29.5	9.5	15.5	22
φ 32	LN01D	53.5	31.5	9.5	15.5	22
φ 40	LN01D	61.5	35.5	9.5	15.5	22
φ 50	LN01D	71.5	40.5	9.5	15.5	22

修理包訂購方式

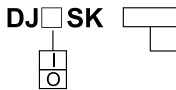

缸徑	修理包	缸徑	修理包
12	DJISK12 - 包含 No.10,12	12	DJOSK12 - 包含 No.9,10,12
16	DJISK16 - 包含 No.10,12	16	DJOSK16 - 包含 No.9,10,12
20	DJISK20 - 包含 No.10,12	20	DJOSK20 - 包含 No.9,10,12
25	DJISK25 - 包含 No.10,12	25	DJOSK25 - 包含 No.9,10,12
32	DJISK32 - 包含 No.10,12	32	DJOSK32 - 包含 No.9,10,12
40	DJISK40 - 包含 No.10,12	40	DJOSK40 - 包含 No.9,10,12
50	DJISK50 - 包含 No.10,12	50	DJOSK50 - 包含 No.9,10,12

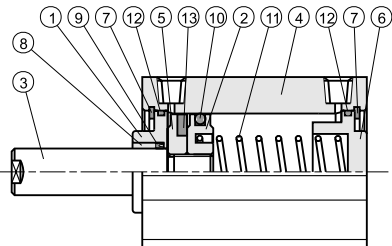
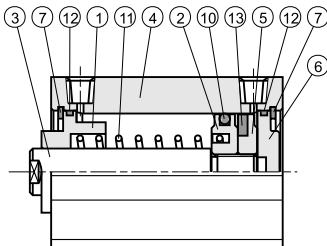

零件表

No.	零件名稱	數量	No.	零件名稱	數量	No.	零件名稱	數量
1	前蓋	1	6	後蓋	1	11	壓縮彈簧	1
2	活塞本體	1	7	孔用扣環	2	12	前後蓋O型環	2
3	活塞桿	1	8	乾式軸承	1	13	磁環	1
4	氣缸本體	1	9	軸封	1	14		
5	磁環座	1	10	活塞迫緊	1	15		

DA

DP

DS

DQ

DB

DN

BN

ST

NT

DU

DJ

TA

GP

GS

GM

GT

RT

CT

CH

DJQ 薄型鋁合金導桿氣缸

雙動導桿氣缸

導桿面板型	DJQ..N	
導桿面板型(附磁性感應)	DJQ..M	
導桿外牙型	DJQ..N..Z	
導桿外牙型(附磁性感應)	DJQ..M..Z	

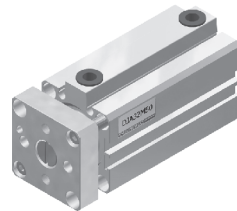

- 全系列可附磁性感應功能。
- 內藏DU自潤軸承，平順度佳。
- 附雙導桿，可承載重負荷。
- 具有兩種外型，設計簡易。
- 外型短，不佔空間。

特性資料

型號	DJQ	DJQ-Z
氣缸內徑 (mm)	φ 20~ φ 63	φ 32~ φ 63
標準行程 (mm)	10,20,30,40,50,60,70,80	
工作媒體	已濾清之壓縮空氣	
使用壓力範圍 (Mpa)	0.1~1.03	
使用溫度範圍 (°C)	-10~+60	

標示法

DJQ 32 N 30 Z - LN01D × 2

型式 	內徑 20-φ 20mm 25-φ 25mm 32-φ 32mm 40-φ 40mm 50-φ 50mm 63-φ 63mm	磁性感應 M:內附磁性感應 N:無附磁性感應	行程 10-10mm 20-20mm 30-30mm 40-40mm 50-50mm 60-60mm 70-70mm 80-80mm	端板型式 NO CODE Z	近接開關 LN01D LN09D	感應器數量 1:1個 2:2個
---------------	---	-------------------------------------	---	-------------------------------------	---------------------------------------	------------------------------

註：
1.可選用NPN&PNP型式 (3線式，24VDC)。
2.可選用輸出接點為接頭型式。
3.請翻閱4-1.3與4-1.5。

氣缸行程與最大扭距曲線圖

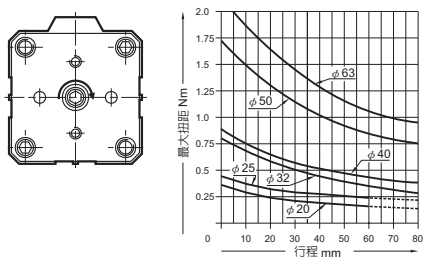

氣缸行程與側面負荷曲線圖

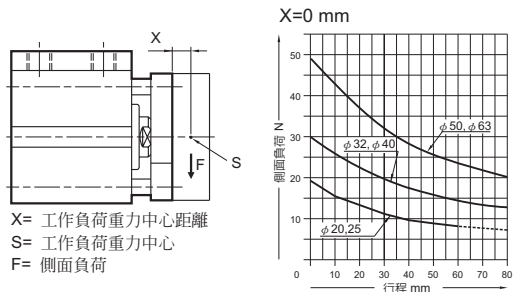

標準行程製作表

內徑	型式 行程	DJQ										DJQ..M								
		10	20	30	40	50	60	75	85	100	10	20	30	40	50	65	75	90		
φ 20		●	●	●	●	●	●	—	—	—	●	●	●	●	●	—	—	—		
φ 25		●	●	●	●	●	●	—	—	—	●	●	●	●	●	—	—	—		

內徑	型式 行程	DJQ								DJQ..Z				DJQ..M DJQ..M..Z								
		10	20	30	40	50	60	75	85	100	10	20	30	40	50	65	75	90				
φ 32		●	●	●	●	●	●	●	—	—	●	●	●	●	●	●	—	—				
φ 40		●	●	●	●	●	●	●	—	—	●	●	●	●	●	●	—	—				
φ 50		●	●	●	●	●	●	●	●	●	●	●	●	●	●	●	●	●				
φ 63		●	●	●	●	●	●	●	●	●	●	●	●	●	●	●	●	●				

感應開關安裝尺寸

缸徑	近接開關型式	A	B	C	D	E
φ 20	LN01D	43.5	26.5	9.5	15.5	22
φ 25	LN01D	49.5	29.5	9.5	15.5	22
φ 32	LN01D	53.5	31.5	9.5	15.5	22
φ 40	LN01D	61.5	35.5	9.5	15.5	22
φ 50	LN01D	71.5	40.5	9.5	15.5	22
φ 63	LN01D	84.5	47	9.5	15.5	22

修理包訂購方式

DJQSK

缸徑	修理包
20	DJQSK20 - 包含 No.12,13,15
25	DJQSK25 - 包含 No.12,13,15
32	DJQSK32 - 包含 No.12,13,15
40	DJQSK40 - 包含 No.12,13,15
50	DJQSK50 - 包含 No.12,13,15
63	DJQSK63 - 包含 No.12,13,15

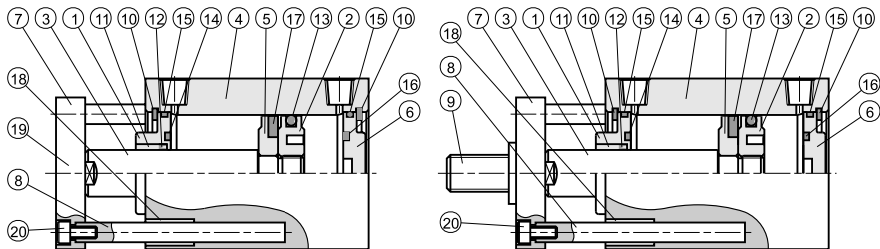

零件表

No.	零件名稱	數量	No.	零件名稱	數量	No.	零件名稱	數量
1	前蓋	1	8	導桿	2	15	前後蓋O型環	2
2	活塞本體	1	9	連接頭	1	16	後蓋墊片	1
3	活塞桿	1	10	孔用扣環	2	17	磁環	1
4	氣缸本體	1	11	乾式軸承	1	18	乾式軸承	2
5	磁環座	1	12	軸封	1	19	繫緊螺絲	1
6	後蓋	1	13	活塞追緊	1	20	繫緊螺絲	2
7	連接板	1	14	前蓋墊片	1	21		

DA

DP

DS

DQ

DB

DN

BN

ST

NT

DU

DJ

TA

GP

GS

GM

GT

RT

CT

CH

雙動型外形尺寸

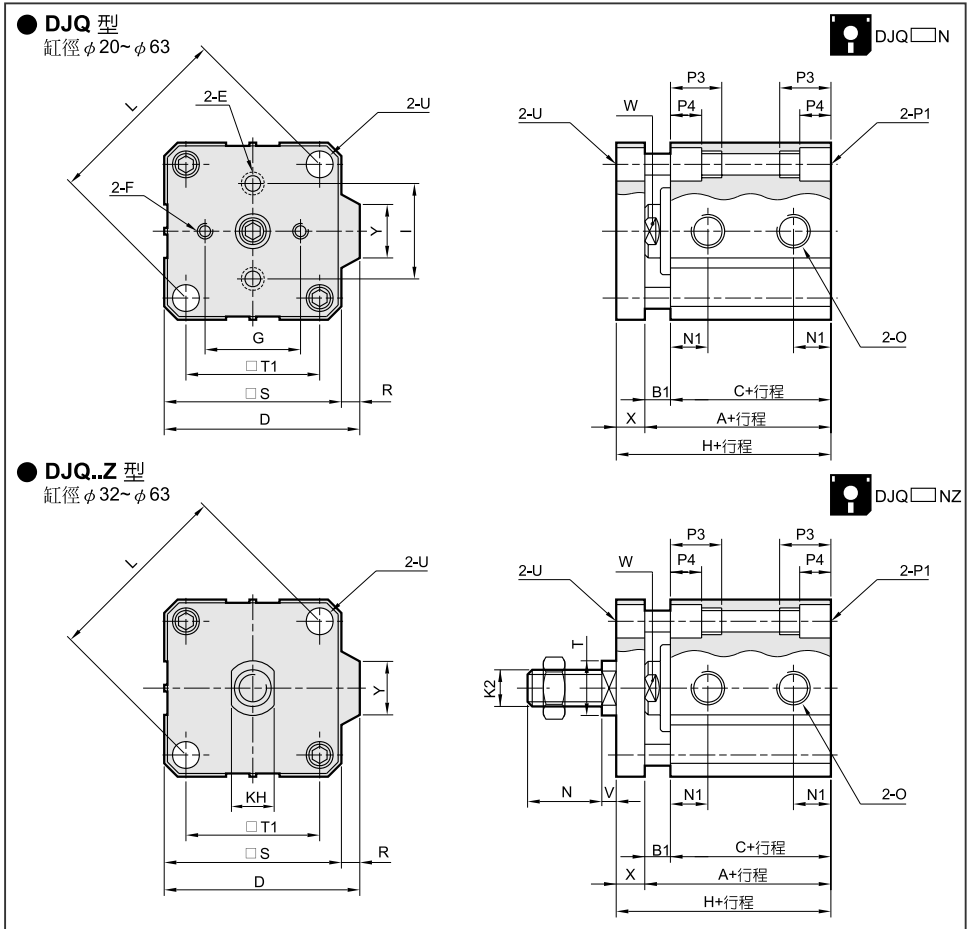

外形尺寸表

右列行程之本體長度“C”尺寸相同: (5,10)(15,20)(25,30)(35,40)(45,50)(55,60)

缸徑	A	B1	C	D	E	F	G	H	I	K2	KH	L	N	N1
φ 20	25	5.5	19.5	—	M6	M6	24	33	24	—	—	34	—	7.5
φ 25	27.2	6	21.2	—	M6	M6	28	35.2	28	—	—	39.6	—	8
φ 32	31	7	24	50	φ 5.5 × φ 10 × 5.5L	M5	28	43	28	M10 × 1.25	22	48	25	9
φ 40	33.5	7	26.5	58	φ 5.5 × φ 10 × 5.5L	M5	33	45.5	33	M14 × 1.5	22	56.5	25	10
φ 50	37.6	9	28.6	71	φ 6.5 × φ 11 × 6.5L	M6	42	49.6	42	M16 × 1.5	22	68	30	10.8
φ 63	41	8.5	32.5	84.5	φ 6.5 × φ 11 × 6.5L	M6	50	53	50	M16 × 1.5	22	85	30	11

缸徑	O	P1	P3	P4	R	S	T	T1	U	V	W	X	Y
φ 20	M5 × 0.8	φ 3.8, 2-柱孔 φ 6.5 × 5深, 2-M5 × 0.8P × 6L	11	5	—	34	—	24	6.5	—	6	8	—
φ 25	M5 × 0.8	φ 5.1, 2-柱孔 φ 8 × 6深, 2-M6 × 1.0P × 8L	14	6	—	40	—	28	6.5	—	8	8	—
φ 32	PT 1/8	φ 5.1, 2-柱孔 φ 8 × 6深, 2-M6 × 1.0P × 8L	14	6	6	44	25	34	8.5	5	10	12	13.6
φ 40	PT 1/8	φ 6.8, 2-柱孔 φ 10 × 8深, 2-M8 × 1.25P × 10L	18	8	6.5	52	25	40	10.5	5	14	12	13.6
φ 50	PT 1/4	φ 6.8, 2-柱孔 φ 10 × 8深, 2-M8 × 1.25P × 10L	18.5	8.5	9.5	62	25	48	10.5	5	17	12	19
φ 63	PT 1/4	φ 6.8, 2-柱孔 φ 10 × 8深, 2-M8 × 1.25P × 10L	18.5	8.5	9.5	75	25	60	10.5	5	17	12	20.5

雙動型附磁性感應外形尺寸

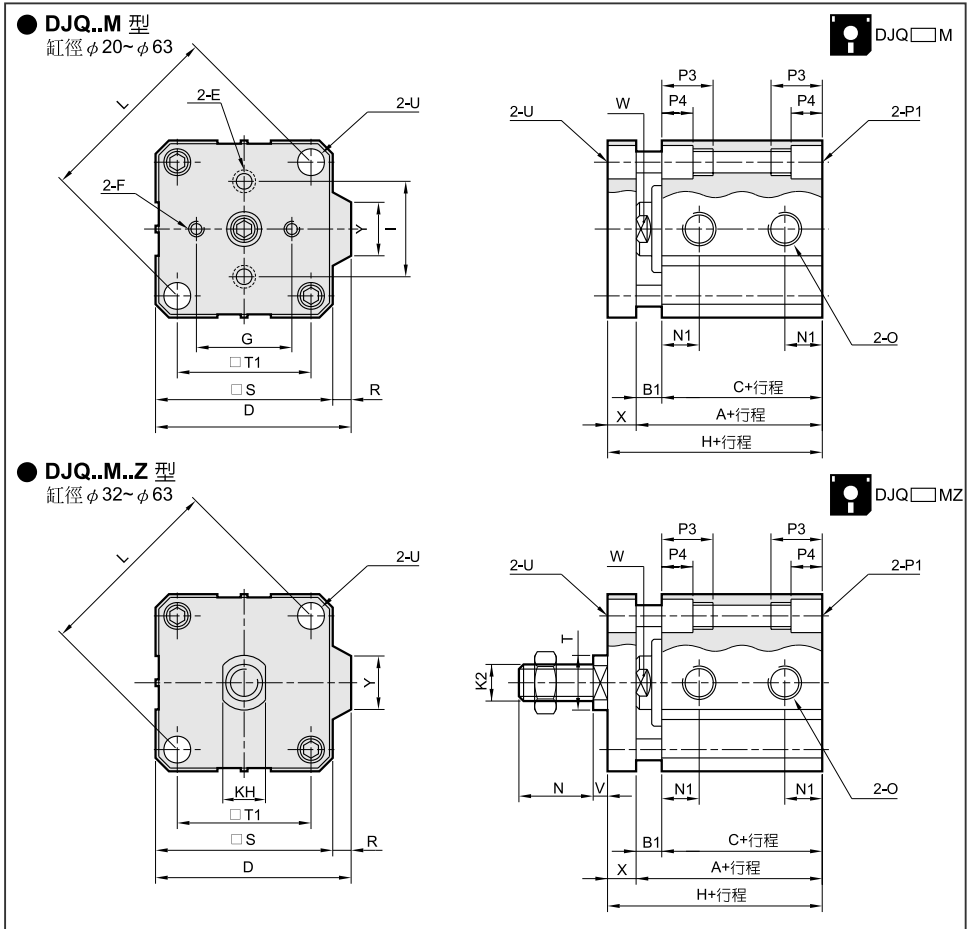

外形尺寸表

右列行程之本體長度“C”尺寸相同: (5,10)(15,20)(25,30)(35,40)(45,50)(55,60)

缸徑	A	B1	C	D	E	F	G	H	I	K2	KH	L	N	N1
φ 20	35	5.5	29.5	—	M6	M6	24	43	24	—	—	34	—	7.5
φ 25	37.2	6	31.2	—	M6	M6	28	45.2	28	—	—	39.6	—	8
φ 32	41	7	34	50	φ 5.5 × φ 10 × 5.5L	M5	28	53	28	M14 × 1.5	22	48	25	9
φ 40	43.5	7	36.5	58	φ 5.5 × φ 10 × 5.5L	M5	33	55.5	33	M14 × 1.5	22	56.5	25	10
φ 50	47.6	9	38.6	71	φ 6.5 × φ 11 × 6.5L	M6	42	59.6	42	M16 × 1.5	22	68	30	10.8
φ 63	51	8.5	42.5	84.5	φ 6.5 × φ 11 × 6.5L	M6	50	63	50	M16 × 1.5	22	85	30	11

缸徑	O	P1	P3	P4	R	S	T	T1	U	V	W	X	Y
φ 20	M5 × 0.8	φ 3.8, 2-柱孔 φ 6.5 × 5深, 2-M5 × 0.8P × 6L	11	5	—	34	—	24	6.5	—	6	8	—
φ 25	M5 × 0.8	φ 5.1, 2-柱孔 φ 8 × 6深, 2-M6 × 1.0P × 8L	14	6	—	40	—	28	6.5	—	8	8	—
φ 32	PT 1/8	φ 5.1, 2-柱孔 φ 8 × 6深, 2-M6 × 1.0P × 8L	14	6	6	44	25	34	8.5	5	10	12	13.6
φ 40	PT 1/8	φ 6.8, 2-柱孔 φ 10 × 8深, 2-M8 × 1.25P × 10L	18	8	6.5	52	25	40	10.5	5	14	12	13.6
φ 50	PT 1/4	φ 6.8, 2-柱孔 φ 10 × 8深, 2-M8 × 1.25P × 10L	18.5	8.5	9.5	62	25	48	10.5	5	17	12	19
φ 63	PT 1/4	φ 6.8, 2-柱孔 φ 10 × 8深, 2-M8 × 1.25P × 10L	18.5	8.5	9.5	75	25	60	10.5	5	17	12	20.5

- DA
- DP
- DS
- DQ
- DB
- DN
- BN
- ST
- NT
- DU
- DJ
- TA
- GP
- GS
- GM
- GT
- RT
- CT
- CH